

AN EFFECTIVE SOLUTION TO SAVE YOUR CROPS

TRACK SYSTEMS YOU CAN COUNT ON



NEW

S-TECH 1000^G
Track Systems for Combine Harvesters

Soucy 

TRACK SYSTEMS FOR COMBINE HARVESTERS

Having access to your fields at harvest time is crucial. With the new S-TECH 1000G, you can work at your own pace, whatever the soil conditions.



QUICK AND EASY INSTALLATION

We know that when it's harvest time, every second counts! The S-TECH 1000G is easy to install. Thanks to its bolt-on design, you can switch from tires to tracks in under 3 hours, ensuring a flexible harvesting plan.

DESIGNED WITH PERFORMANCE IN MIND

The S-TECH 1000G was built to perform throughout long hours of work. You can expect speeds of up to 17.5 mph (28 km/h) and a maximum load capacity on the field of 65,000 lbs (29,500 kg).

BETTER MANEUVERABILITY

The S-TECH 1000G has a more compact design. This means more maneuverability for you. Turning at the end of the field has never been easier!

OPTIMAL FLOTATION

You can bank on optimal flotation. Even in difficult soil conditions, the track's 36 in (914 mm) width and 5,710 in² (3.68 m²) ground contact surface enable you to harvest confidently.

MINIMAL MAINTENANCE

Thanks to its oil bath hubs, the S-TECH 1000G won't need daily maintenance. You can optimize your work time and carry out maintenance on the track system after 500 hours of work or once a year.

EVEN MORE DURABLE

The rubber-coated UHMW plastic wheels increase the service life of both wheels and tracks. The S-TECH 1000G is designed to be a fellow worker you can count on.



TECHNICAL SPECIFICATIONS

COMBINE HARVESTER



S-TECH 1000G

A	36 in 914 mm
B	114.1 in 2,899 mm
C	68 in 1,728 mm
D	40 in 1,016 mm
E	28 in 711 mm
F	14.5 in 368 mm
Total ground contact area	Per kit of 2 tracks 5,710 in ² 3.68 m ²

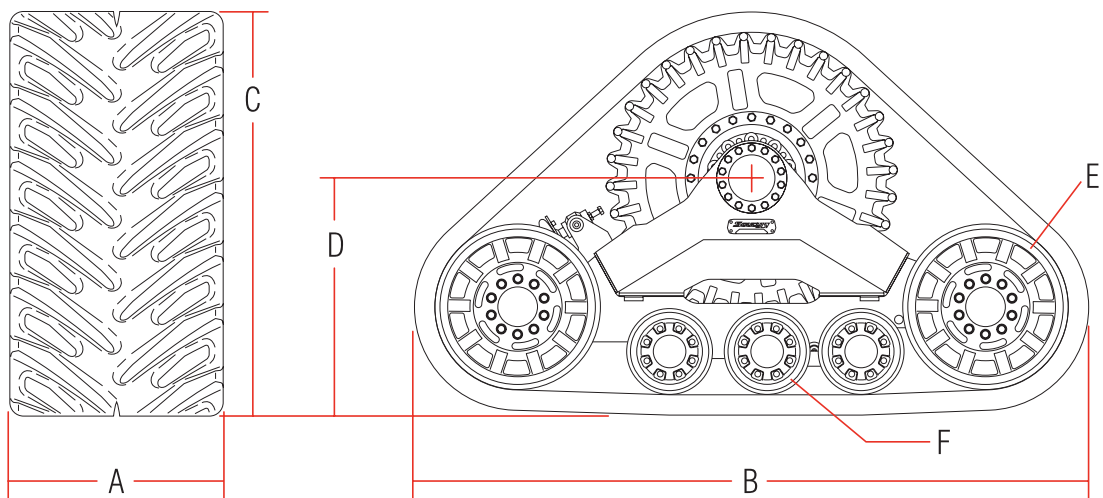

Visit soucy-track.com for all of our track systems' vehicle compatibility details.



SUPER AGILE SALES NETWORK TO SERVE YOU QUICKLY AND EFFICIENTLY

Our extensive network of trusted dealers and distributors makes it possible to better serve farmers all around the world.

Our priority: to provide a simple and flexible solution allowing you to get out into the fields at the right time, with a tool you can trust.

To see all our points of sale or for further information, go to **soucy-track.com**.

Toll-Free
(Canada/United States)
1 877 474-6665

International
1 800 9118-7225

Email
soucy.track@soucy-group.com

