

*Soucy* 

# HD4 PRO

THE ULTIMATE HEAVY-DUTY  
4 SEASON UTV TRACK SYSTEM

Your  
*off-road*  
partner.



## A TRUE 4 SEASON KIT

### No lateral plastic slide guide

The only high traction heavy-duty system to use wheel guided tracks without the use of a plastic slide. Confidently work with your system all summer long without having to worry about slide meltdowns.

### Unbeatable in mud and water, with the greatest resistance to immersion.

Optimal multi-level protection of bearings against water and dirt infiltration for the highest lifespan in the market.

- Completely sealed exterior of the main axle bearings.
- Triple-lip greased seals to prevent water and mud infiltration into the main axle and wheel bearings (Patent Pending).
- Screw-on wheel caps that stay in place (Patent Pending).
- Sealed to prevent any contamination.
- Stainless-steel protective plate to prevent debris from damaging seals.

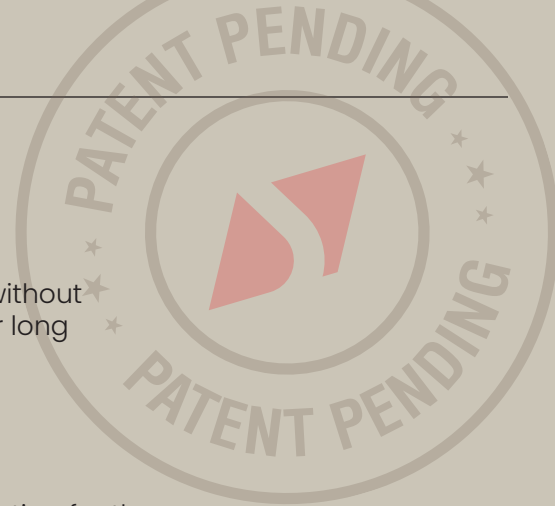

## BUILT FOR OPTIMAL DURABILITY - with premium components

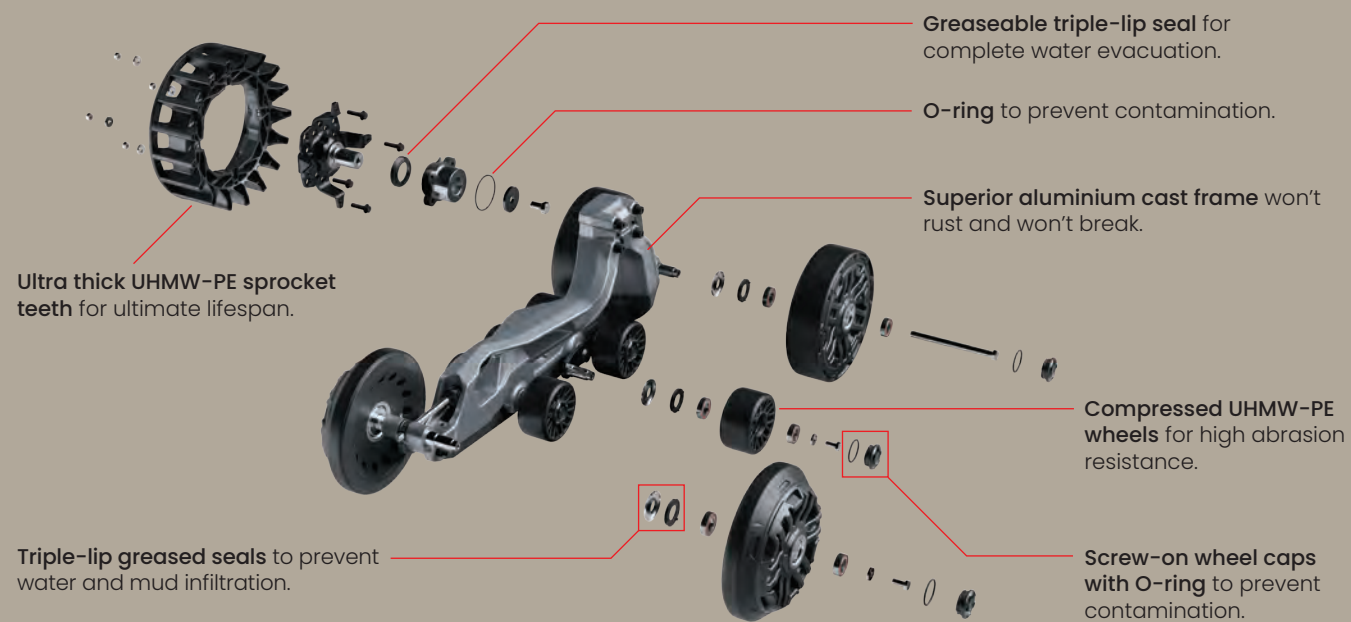

## COMFORT WITHOUT COMPROMISE

### For Long Working Hours

- Optimized tread design for a smoother ride and noise reduction.
- Rear tandem wheels maximize shock absorption for higher comfort on rough terrains.
- Wheel spacing optimized for low vibration.
- Continuous slide to remove bumping from one wheel to the other.
- Thick rubber tire on idler wheels to absorb impacts.
- Shortest turn radius on the market due to very aggressive front track tread.

## PAYLOAD CAPACITY

### 4,000 lb load capacity

The most robust components in the industry to support and transport heavy loads with materials boasting superior strength-to-weight ratios.

- Massive double-row tapered roller bearings for the main axle.
- Extra wide traction lug design for torque transmission. Efficient torque transmission necessary for carrying heavy loads going uphill or towing heavy load and effectively resisting detracking.

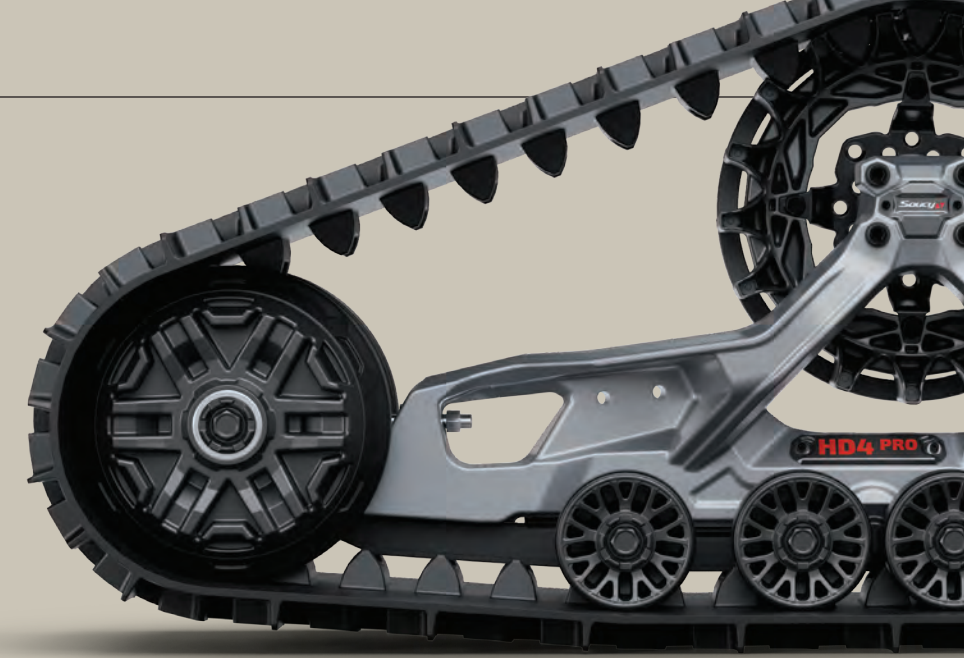

## QUALITY MATERIALS - for superior strength-to-weight-ratio

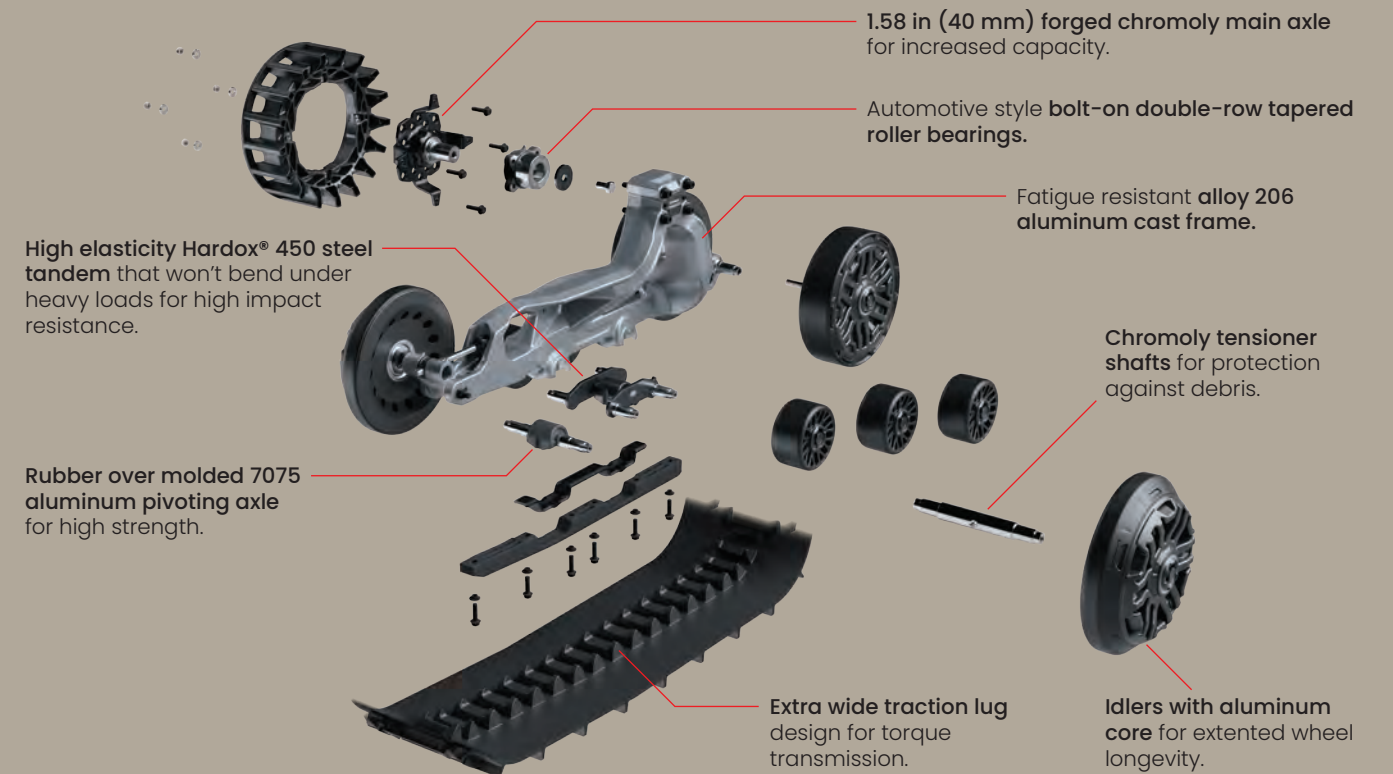

## MINIMAL MAINTENANCE

### Robust and Durable Design

- Entirely pressure washer resistant with bearings sealed to withstand harsh conditions.
- Main axle bearing can be easily removed by 4 bolts.
- Integrated grease port on the main axle and tensioners for complete water evacuation after prolonged immersion.
- Extremely durable components reduce part replacements to a minimum.
- Easily adjustable track tension with a visual indicator.
- 3-Year Warranty, the Best in class.

# HIGH CAPACITY – DURABILITY – LOW MAINTENANCE

With a 4,000 lb (1,815 kg) load capacity, it's the most robust and durable system on the market. It excels in mud and snow with high traction and performs quietly and comfortably on rough terrain. Made from premium materials, with optimized design features it ensures minimal maintenance.

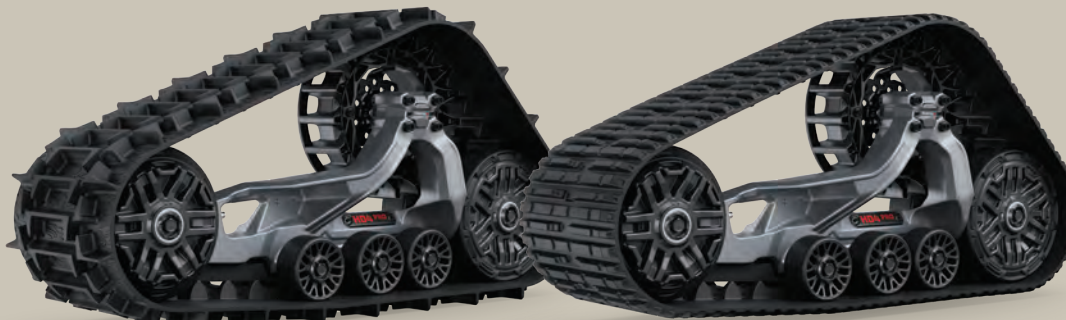

Performance

Industrial

## TECHNICAL SPECIFICATIONS

### TRACK

<b>Width</b>	Front: 12.5 in (317.5 mm) Rear: 14 in (355.6 mm)
<b>Length</b>	Front: 100 in (2,540 mm) Rear: 116.7 in (2,964 mm)
<b>Lug Height</b>	Performance Track: 1.125 in (28.6 mm)



### Performance

Aggressive track design to give you the best traction possible on every surface.

### Industrial

Track design minimizes ground damage.

### SYSTEM

<b>Weight</b>	Front: 136 lb (61.7 kg) Rear: 182 lb (82.6 kg)
<b>Width</b>	Front: 12.5 in (317.5 mm) Rear: 14 in (355.6 mm)
<b>Length</b>	Front: 42.8 in (1,086 mm) Rear: 50.8 in (1,290 mm)
<b>Height</b>	Front: 25.2 in (640 mm) Rear: 25.2 in (641 mm)
<b>Ground Clearance Offset (average)</b>	+ 5 in (127 mm)
<b>Offset Width</b>	Front: 7.25 in (184.2 mm) Rear: 8 in (203.2 mm)
<b>Offset Length</b>	Front: 27 in (686 mm) Rear: 33 in (838 mm)
<b>Ground Clearance</b>	Front: 16.38 in (416 mm) Rear: 16.5 in (419 mm)
<b>Ground Surface</b>	2,482 in <sup>2</sup> (1.60 m <sup>2</sup> )
<b>Maintained Speed (average)</b>	2/3
<b>Compatibility</b>	Kubota RTV-XG and RTV-X range

Contact Us  
Toll-Free (Canada/United States)  
**1 855 5TRACKS (1 855 587-2257)**  
[service@soucy-track.com](mailto:service@soucy-track.com)

[soucy-track.com](http://soucy-track.com)

